

Endometrioid Epithelial Ovarian Cancer Treatment and Follow-up Pathway Map

Version 2018.06

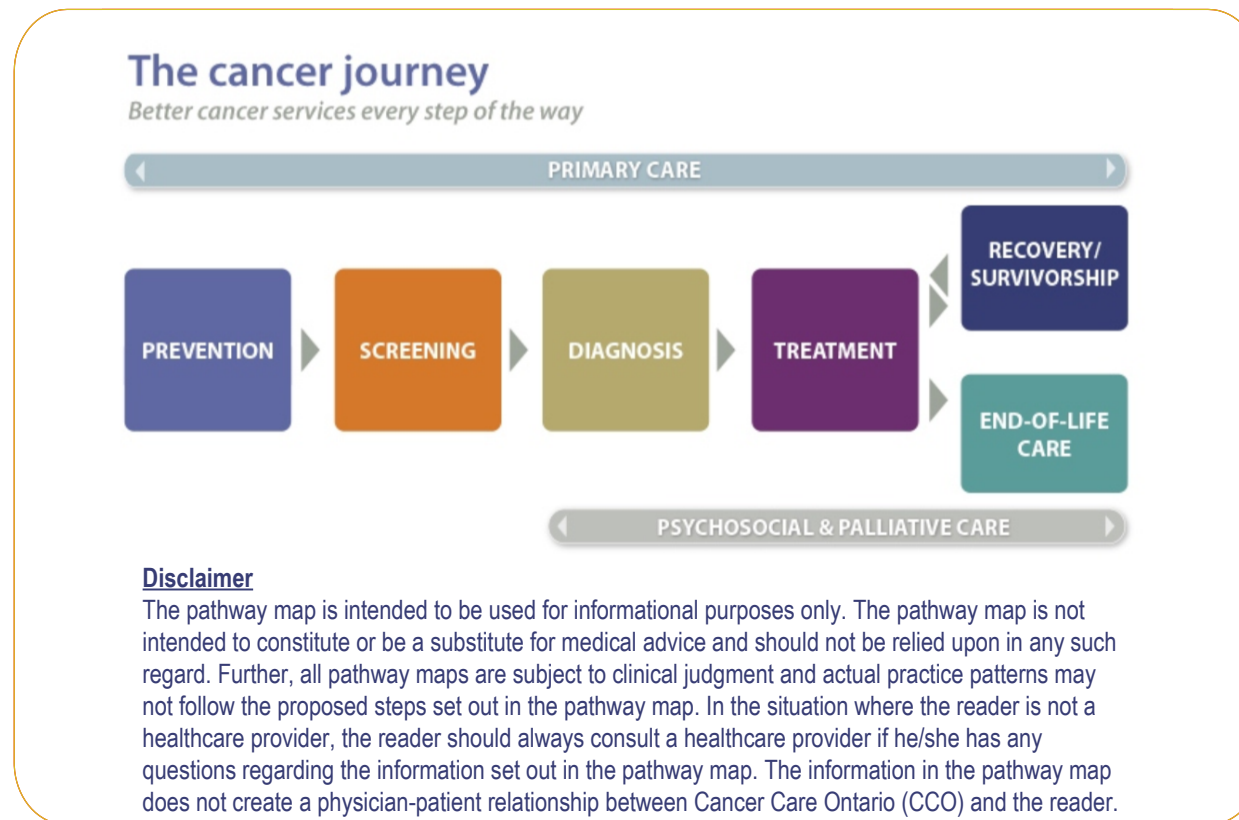

Target Population

- Women presenting with epithelial ovarian cancer









Pathway Map Considerations

- For more information about the optimal organization of gynecologic oncology services in Ontario refer to [EBS #4-11](#)
- The staging system used throughout the Ovarian Cancer Treatment Pathway is the 2014 FIGO staging system.
- Primary care providers play an important role in the cancer journey and should be informed of relevant tests and consultations. Ongoing care with a primary care provider is assumed to be part of the pathway map. For patients who do not have a primary care provider, [Health Care Connect](#), is a government resource that helps patients find a doctor or nurse practitioner.
- Throughout the pathway map, a shared decision-making model should be implemented to enable and encourage patients to play an active role in the management of their care. For more information see [Person-Centered Care Guideline](#) and [EBS #19-2 Provider-Patient Communication*](#)
- Hyperlinks are used throughout the pathway map to provide information about relevant CCO tools, resources and guidance documents.
- The term 'healthcare provider', used throughout the pathway map, includes primary care providers and specialists, e.g. family doctors, nurse practitioners, gynecologists, midwives and emergency physicians.
- For more information on Multidisciplinary Cancer Conferences visit [MCC Tools](#)
- For more information on wait time prioritization, visit: [Surgery](#)
- Clinical trials should be considered for all phases of the pathway map.
- Psychosocial oncology (PSO) is the interprofessional specialty concerned with understanding and treating the social, practical, psychological, emotional, spiritual and functional needs and quality-of-life impact that cancer has on patients and their families. Psychosocial care should be considered an integral and standardized part of cancer care for patients and their families at all stages of the illness trajectory. For more information, visit [EBS #19-3*](#)
- The following should be considered when weighing the treatment options described in this pathway map for patients with potentially life-limiting illness:
 - Palliative care may be of benefit at any stage of the cancer journey, and may enhance other types of care – including restorative or rehabilitative care – or may become the total focus of care
 - Ongoing discussions regarding goals of care is central to palliative care, and is an important part of the decision-making process. Goals of care discussions include the type, extent and goal of a treatment or care plan, where care will be provided, which health care providers will provide the care, and the patient's overall approach to care









* **Note.** [EBS #19-2](#) and [EBS #19-3](#) are older than 3 years and are currently listed as 'For Education and Information Purposes'. This means that the recommendations will no longer be maintained but may still be useful for academic or other information purposes.

Pathway Map Legend

Colour Guide

	Primary Care
	Palliative Care
	Pathology
	Diagnostic Assessment Program (DAP)
	Gynecologic Oncology
	Radiation Oncology
	Medical Oncology
	Radiology
	Gynecology
	Genetics
	Multidisciplinary Cancer Conference (MCC)

Shape Guide

	Intervention
	Decision or assessment point
	Patient (disease) characteristics
	Consultation with specialist
	Exit pathway
	Off-page reference
	Patient/Provider interaction
	Referral
	Wait time indicator time point

Line Guide

	Required
	Possible

Pathway Map Disclaimer

This pathway map is a resource that provides an overview of the treatment that an individual in the Ontario cancer system may receive.

The pathway map is intended to be used for informational purposes only. The pathway map is not intended to constitute or be a substitute for medical advice and should not be relied upon in any such regard. Further, all pathway maps are subject to clinical judgment and actual practice patterns may not follow the proposed steps set out in the pathway map. In the situation where the reader is not a healthcare provider, the reader should always consult a healthcare provider if he/she has any questions regarding the information set out in the pathway map. The information in the pathway map does not create a physician-patient relationship between Cancer Care Ontario (CCO) and the reader.

While care has been taken in the preparation of the information contained in the pathway map, such information is provided on an "as-is" basis, without any representation, warranty, or condition, whether express, or implied, statutory or otherwise, as to the information's quality, accuracy, currency, completeness, or reliability.

CCO and the pathway map's content providers (including the physicians who contributed to the information in the pathway map) shall have no liability, whether direct, indirect, consequential, contingent, special, or incidental, related to or arising from the information in the pathway map or its use thereof, whether based on breach of contract or tort (including negligence), and even if advised of the possibility thereof. Anyone using the information in the pathway map does so at his or her own risk, and by using such information, agrees to indemnify CCO and its content providers from any and all liability, loss, damages, costs and expenses (including legal fees and expenses) arising from such person's use of the information in the pathway map.

This pathway map may not reflect all the available scientific research and is not intended as an exhaustive resource. CCO and its content providers assume no responsibility for omissions or incomplete information in this pathway map. It is possible that other relevant scientific findings may have been reported since completion of this pathway map. This pathway map may be superseded by an updated pathway map on the same topic.

The pathway map is intended to be used for informational purposes only. The pathway map is not intended to constitute or be a substitute for medical advice and should not be relied upon in any such regard. Further, all pathway maps are subject to clinical judgment and actual practice patterns may not follow the proposed steps set out in the pathway map. In the situation where the reader is not a healthcare provider, the reader should always consult a healthcare provider if he/she has any questions regarding the information set out in the pathway map. The information in the pathway map does not create a physician-patient relationship between Cancer Care Ontario (CCO) and the reader.

Screen for psychosocial needs, and assessment and management of symptoms. [Click here for more information about symptom assessment and management tools](#)

Consider the introduction of palliative care, early and across the cancer journey [Click here for more information about palliative care](#)

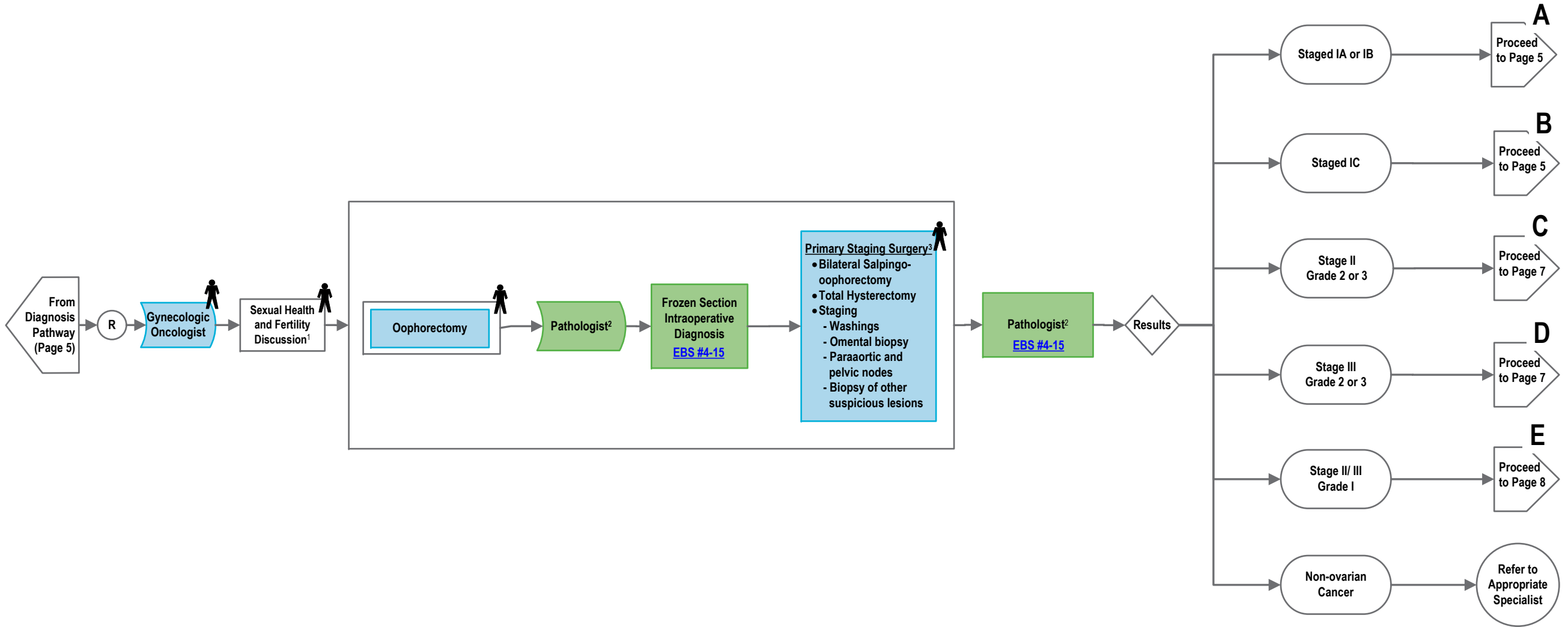

¹ Discussion to be individualized for each patient; however, may include the following: age, fertility preservation, hormone replacement therapy, referral for infertility consultation, etc

² Pathologists with a specialty or special interest in gynecologic pathology.

³ If appropriate, the option of fertility sparing surgery should be discussed with the patient.

The pathway map is intended to be used for informational purposes only. The pathway map is not intended to constitute or be a substitute for medical advice and should not be relied upon in any such regard. Further, all pathway maps are subject to clinical judgment and actual practice patterns may not follow the proposed steps set out in the pathway map. In the situation where the reader is not a healthcare provider, the reader should always consult a healthcare provider if he/she has any questions regarding the information set out in the pathway map. The information in the pathway map does not create a physician-patient relationship between Cancer Care Ontario (CCO) and the reader.

Screen for psychosocial needs, and assessment and management of symptoms. [Click here for more information about symptom assessment and management tools](#)

Consider the introduction of palliative care, early and across the cancer journey [Click here for more information about palliative care](#)

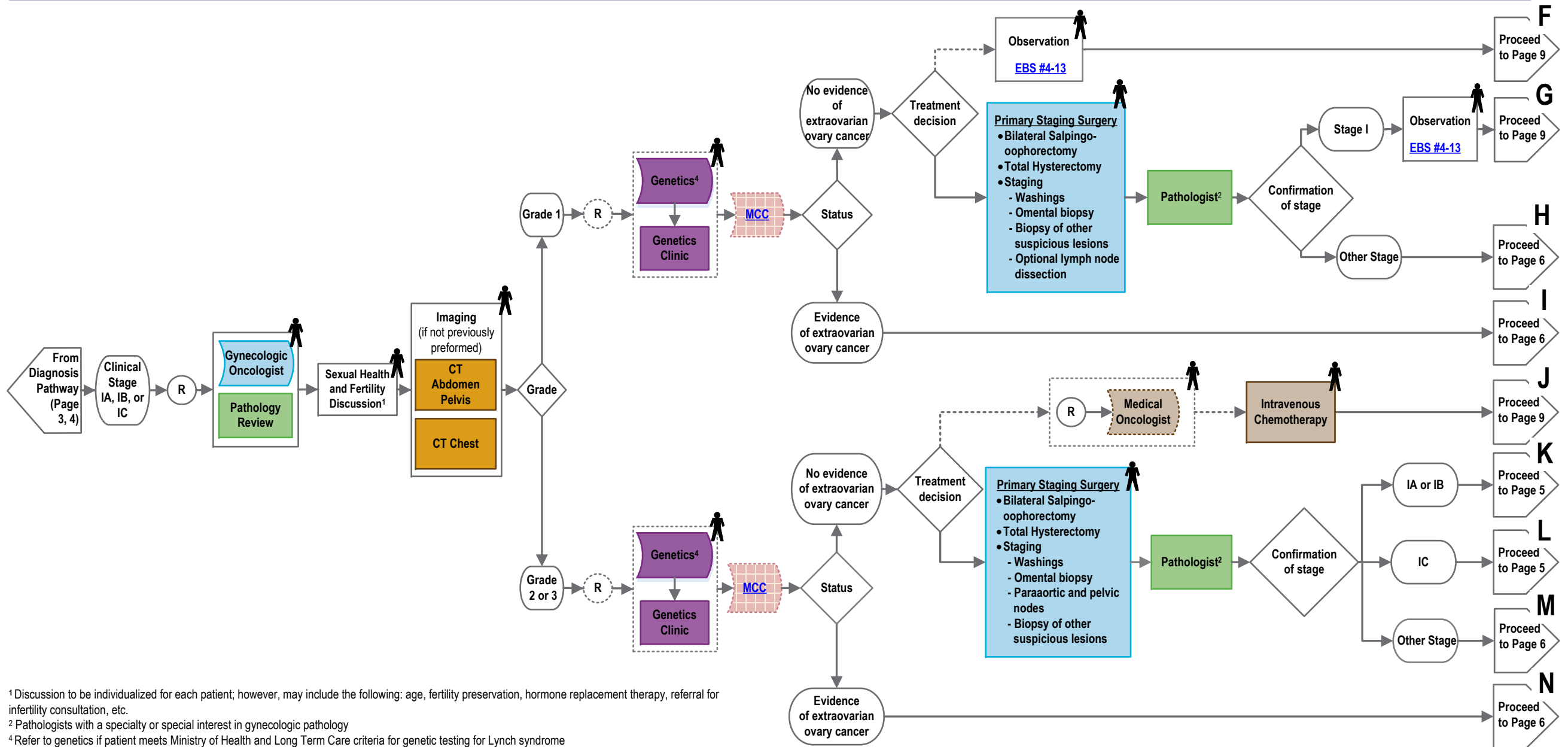

¹ Discussion to be individualized for each patient; however, may include the following: age, fertility preservation, hormone replacement therapy, referral for infertility consultation, etc.

² Pathologists with a specialty or special interest in gynecologic pathology

⁴ Refer to genetics if patient meets Ministry of Health and Long Term Care criteria for genetic testing for Lynch syndrome

The pathway map is intended to be used for informational purposes only. The pathway map is not intended to constitute or be a substitute for medical advice and should not be relied upon in any such regard. Further, all pathway maps are subject to clinical judgment and actual practice patterns may not follow the proposed steps set out in the pathway map. In the situation where the reader is not a healthcare provider, the reader should always consult a healthcare provider if he/she has any questions regarding the information set out in the pathway map. The information in the pathway map does not create a physician-patient relationship between Cancer Care Ontario (CCO) and the reader.

Screen for psychosocial needs, and assessment and management of symptoms. [Click here for more information about symptom assessment and management tools](#)

Consider the introduction of palliative care, early and across the cancer journey [Click here for more information about palliative care](#)

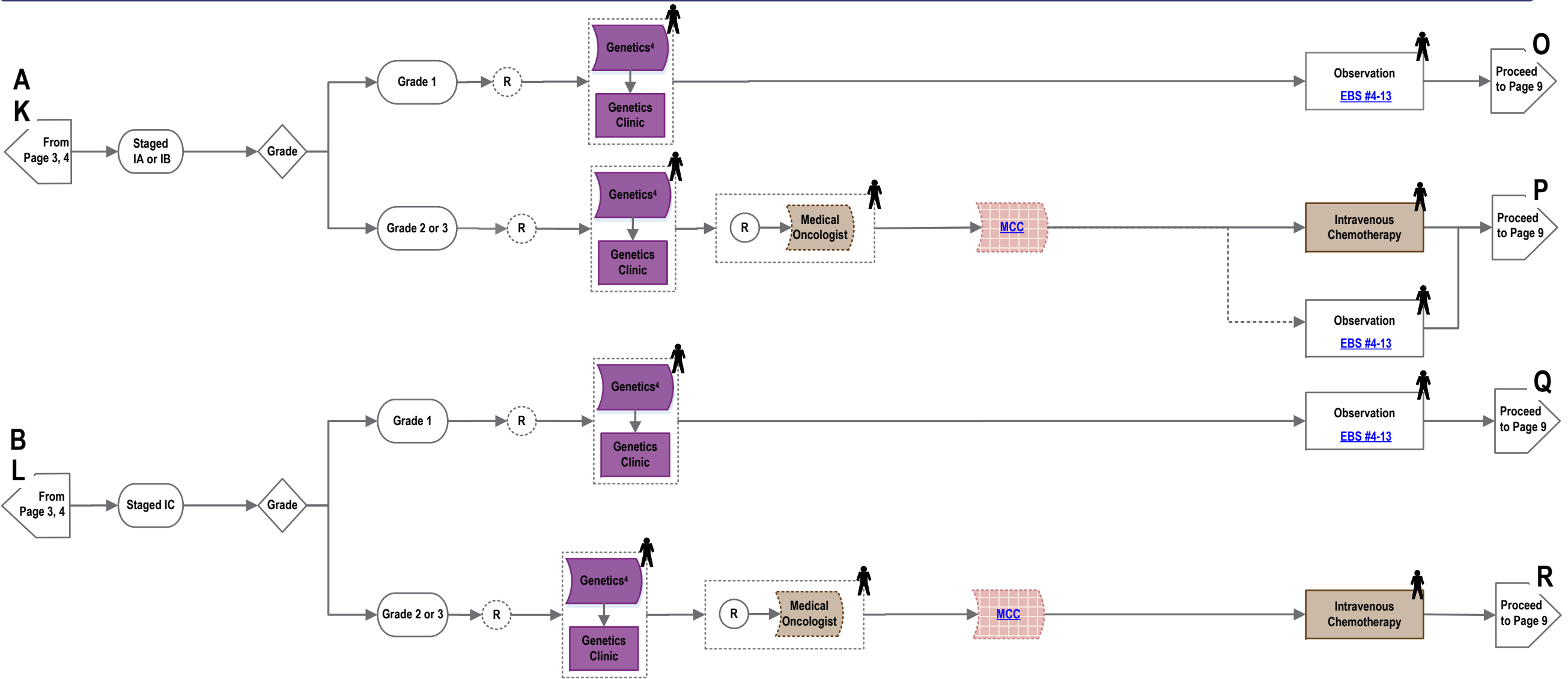

⁴ Refer to genetics if patient meets Ministry of Health and Long Term Care criteria for genetic testing for Lynch syndrome

The pathway map is intended to be used for informational purposes only. The pathway map is not intended to constitute or be a substitute for medical advice and should not be relied upon in any such regard. Further, all pathway maps are subject to clinical judgment and actual practice patterns may not follow the proposed steps set out in the pathway map. In the situation where the reader is not a healthcare provider, the reader should always consult a healthcare provider if he/she has any questions regarding the information set out in the pathway map. The information in the pathway map does not create a physician-patient relationship between Cancer Care Ontario (CCO) and the reader.

Screen for psychosocial needs, and assessment and management of symptoms. [Click here for more information about symptom assessment and management tools](#)

Consider the introduction of palliative care, early and across the cancer journey [Click here for more information about palliative care](#)

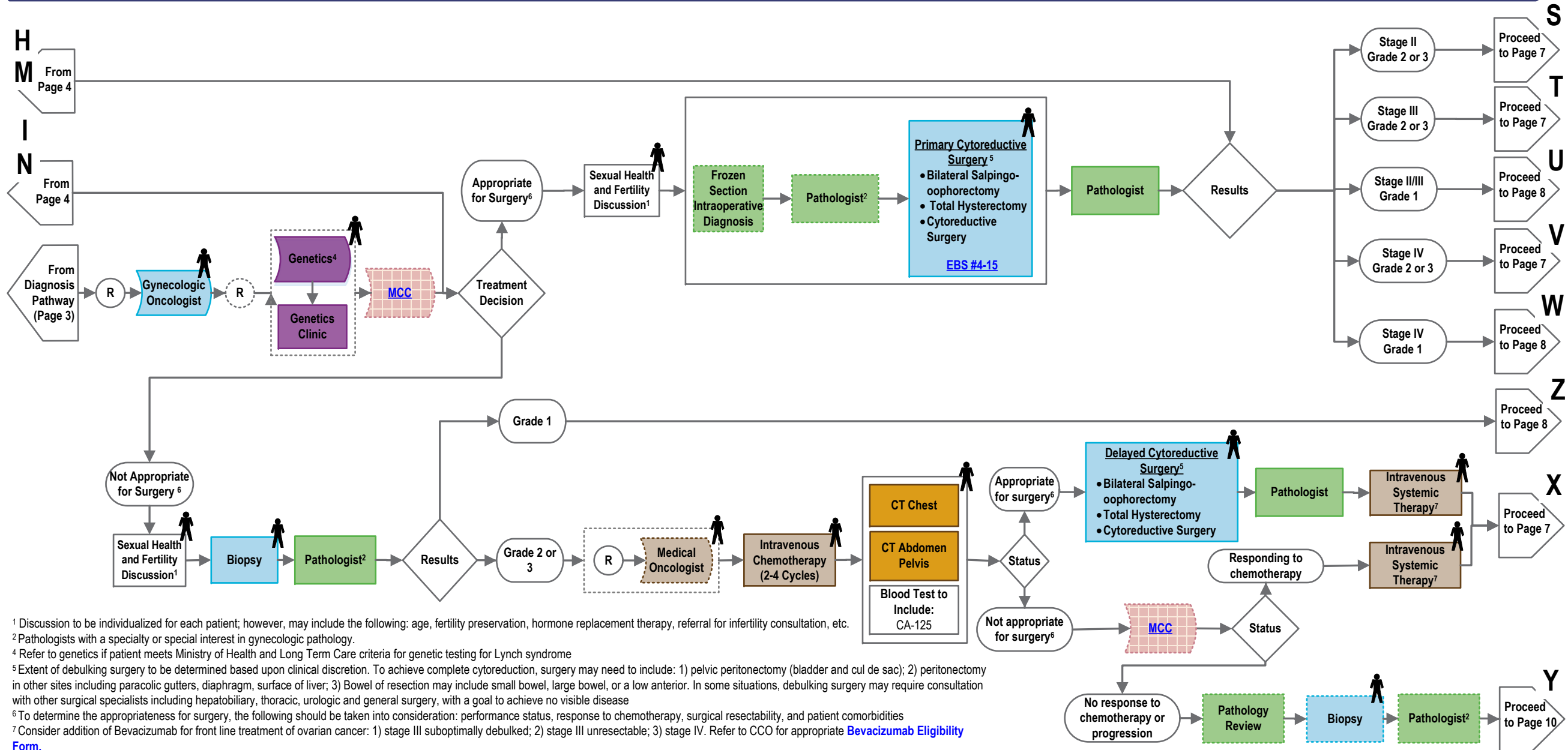

¹ Discussion to be individualized for each patient; however, may include the following: age, fertility preservation, hormone replacement therapy, referral for infertility consultation, etc.
² Pathologists with a specialty or special interest in gynecologic pathology.
⁴ Refer to genetics if patient meets Ministry of Health and Long Term Care criteria for genetic testing for Lynch syndrome
⁵ Extent of debulking surgery to be determined based upon clinical discretion. To achieve complete cytoreduction, surgery may need to include: 1) pelvic peritonectomy (bladder and cul de sac); 2) peritonectomy in other sites including paracolic gutters, diaphragm, surface of liver; 3) Bowel of resection may include small bowel, large bowel, or a low anterior. In some situations, debulking surgery may require consultation with other surgical specialists including hepatobiliary, thoracic, urologic and general surgery, with a goal to achieve no visible disease
⁶ To determine the appropriateness for surgery, the following should be taken into consideration: performance status, response to chemotherapy, surgical resectability, and patient comorbidities
⁷ Consider addition of Bevacizumab for front line treatment of ovarian cancer: 1) stage III suboptimally debulked; 2) stage III unresectable; 3) stage IV. Refer to CCO for appropriate [Bevacizumab Eligibility Form](#).

The pathway map is intended to be used for informational purposes only. The pathway map is not intended to constitute or be a substitute for medical advice and should not be relied upon in any such regard. Further, all pathway maps are subject to clinical judgment and actual practice patterns may not follow the proposed steps set out in the pathway map. In the situation where the reader is not a healthcare provider, the reader should always consult a healthcare provider if he/she has any questions regarding the information set out in the pathway map. The information in the pathway map does not create a physician-patient relationship between Cancer Care Ontario (CCO) and the reader.

Screen for psychosocial needs, and assessment and management of symptoms. [Click here for more information about symptom assessment and management tools](#)

Consider the introduction of palliative care, early and across the cancer journey [Click here for more information about palliative care](#)

Please note: EBS #4-21 is currently listed as 'For Education and Information Purposes'. This means that the recommendations will no longer be maintained but may still be useful for academic or other informational purposes.

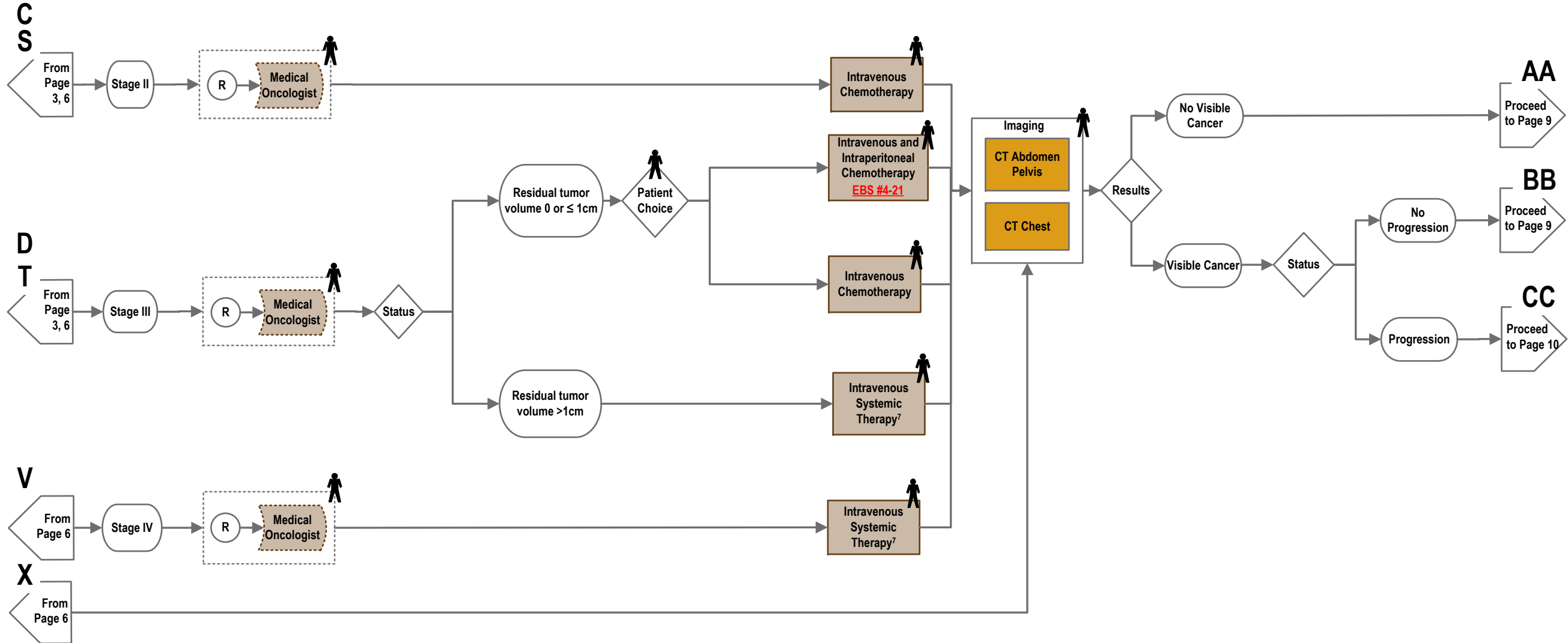

⁷ Consider addition of Bevacizumab for front line treatment of ovarian cancer: 1) stage III suboptimally debulked; 2) stage III unresectable; 3) stage IV. Refer to CCO for appropriate [Bevacizumab Eligibility Form](#)

The pathway map is intended to be used for informational purposes only. The pathway map is not intended to constitute or be a substitute for medical advice and should not be relied upon in any such regard. Further, all pathway maps are subject to clinical judgment and actual practice patterns may not follow the proposed steps set out in the pathway map. In the situation where the reader is not a healthcare provider, the reader should always consult a healthcare provider if he/she has any questions regarding the information set out in the pathway map. The information in the pathway map does not create a physician-patient relationship between Cancer Care Ontario (CCO) and the reader.

Screen for psychosocial needs, and assessment and management of symptoms. [Click here for more information about symptom assessment and management tools](#)

Consider the introduction of palliative care, early and across the cancer journey [Click here for more information about palliative care](#)

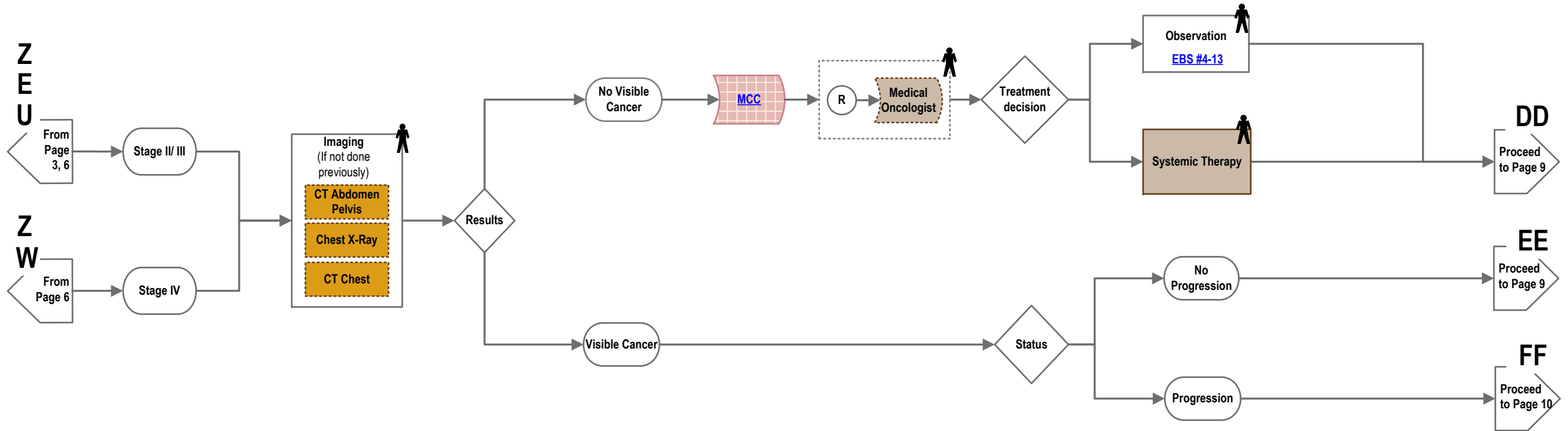

The pathway map is intended to be used for informational purposes only. The pathway map is not intended to constitute or be a substitute for medical advice and should not be relied upon in any such regard. Further, all pathway maps are subject to clinical judgment and actual practice patterns may not follow the proposed steps set out in the pathway map. In the situation where the reader is not a healthcare provider, the reader should always consult a healthcare provider if he/she has any questions regarding the information set out in the pathway map. The information in the pathway map does not create a physician-patient relationship between Cancer Care Ontario (CCO) and the reader.

Screen for psychosocial needs, and assessment and management of symptoms. [Click here for more information about symptom assessment and management tools](#)

Consider the introduction of palliative care, early and across the cancer journey [Click here for more information about palliative care](#)

F
G
J
O
P
Q
R
AA
BB
DD
EE

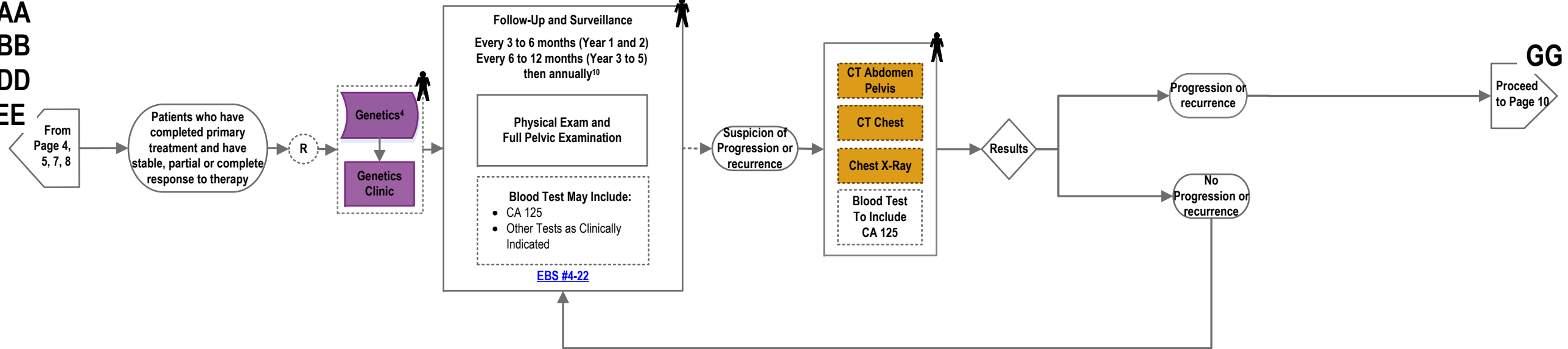

⁴ Refer to genetics if patient meets Ministry of Health and Long Term Care criteria for genetic testing for Lynch syndrome

¹⁰ Annual follow-up by gynecologist, family doctor or gynecologic oncologist.

The pathway map is intended to be used for informational purposes only. The pathway map is not intended to constitute or be a substitute for medical advice and should not be relied upon in any such regard. Further, all pathway maps are subject to clinical judgment and actual practice patterns may not follow the proposed steps set out in the pathway map. In the situation where the reader is not a healthcare provider, the reader should always consult a healthcare provider if he/she has any questions regarding the information set out in the pathway map. The information in the pathway map does not create a physician-patient relationship between Cancer Care Ontario (CCO) and the reader.

Screen for psychosocial needs, and assessment and management of symptoms. [Click here for more information about symptom assessment and management tools](#)

Consider the introduction of palliative care, early and across the cancer journey [Click here for more information about palliative care](#)

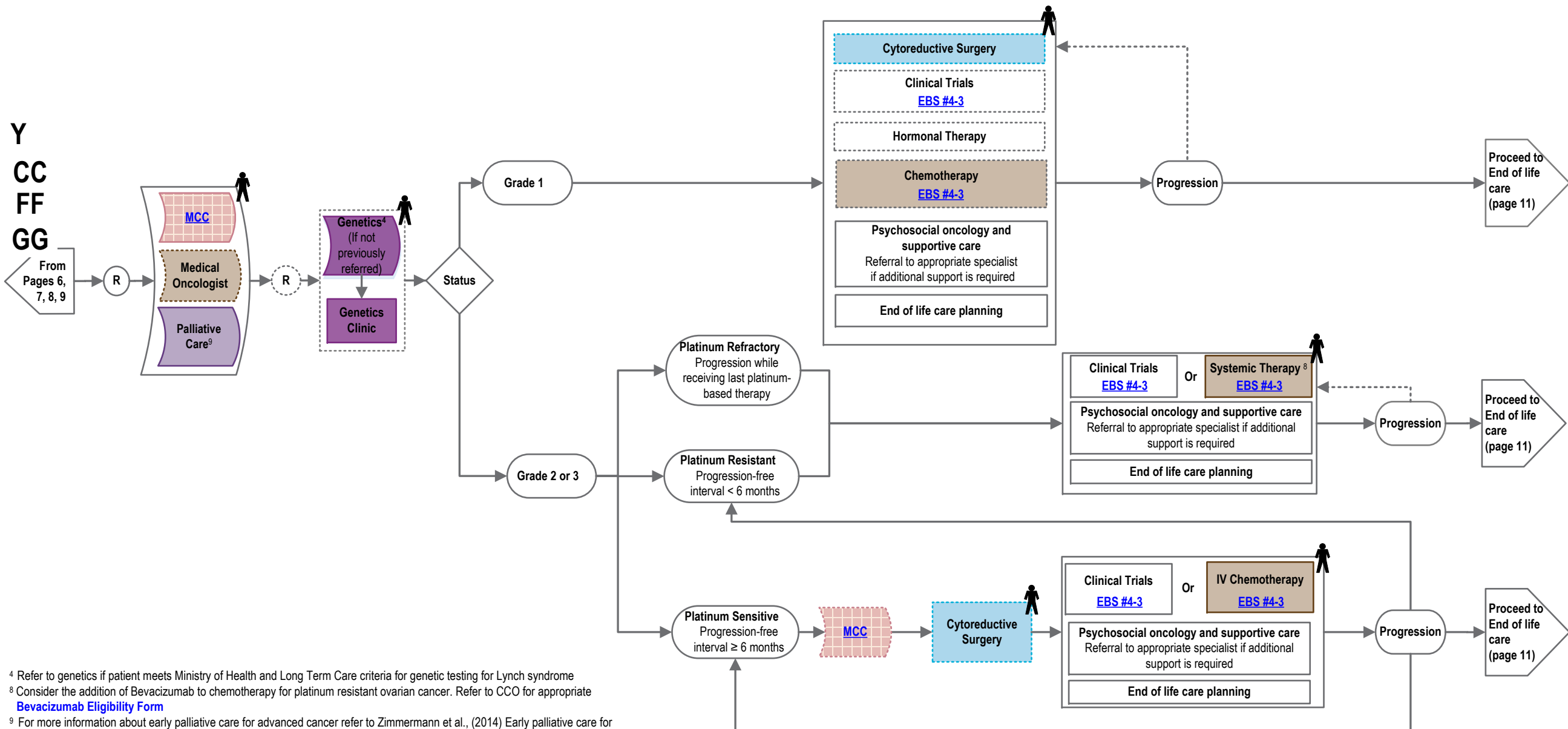

⁴ Refer to genetics if patient meets Ministry of Health and Long Term Care criteria for genetic testing for Lynch syndrome

⁸ Consider the addition of Bevacizumab to chemotherapy for platinum resistant ovarian cancer. Refer to CCO for appropriate [Bevacizumab Eligibility Form](#)

⁹ For more information about early palliative care for advanced cancer refer to Zimmermann et al., (2014) Early palliative care for patients with advanced cancer: a cluster-randomized controlled trial. *Lancet*, 383(9930), 1721-30.

The pathway map is intended to be used for informational purposes only. The pathway map is not intended to constitute or be a substitute for medical advice and should not be relied upon in any such regard. Further, all pathway maps are subject to clinical judgment and actual practice patterns may not follow the proposed steps set out in the pathway map. In the situation where the reader is not a healthcare provider, the reader should always consult a healthcare provider if he/she has any questions regarding the information set out in the pathway map. The information in the pathway map does not create a physician-patient relationship between Cancer Care Ontario (CCO) and the reader.

Pathway Map Target Population:
 Individuals with cancer approaching end of life, and their families.
 While this section of the pathway map is focused on the care delivered at the end of life, the palliative care approach begins much earlier on in the illness trajectory. Refer to [Screen, Assess & Plan](#) within the Psychosocial & Palliative Care Pathway Map

Triggers that suggest patients are nearing the last few months and weeks life

- ECOG/Patient-ECOG/PRFS = 4 OR
- PPS ≤ 30
- Declining performance status/functional ability
- Gold Standards Framework indicators of high mortality risk

[Screen, Assess, Plan, Manage and Follow-Up](#)

+

End of Life Care planning and implementation
 Collaboration and consultation between specialist-level care teams and primary care teams

End of Life Care

- Revisit Advance Care Planning**
 - Ensure the patient has determined who will be their Substitute Decision Maker (SDM)
 - Ensure the patient has communicated to the SDM his/her wishes, values and beliefs to help guide that SDM in future decision making
- Discuss and document goals of care with patient and family**
 - Assess and address patient and family's information needs and understanding of the disease, address gaps between reality and expectation, foster realistic hope and provide opportunity to explore prognosis and life expectancy, and preparedness for death
 - Introduce patient and family to resources in community (e.g., day hospice programs)
- Develop a plan of treatment and obtain consent**
 - Determine who the person wants to include in the decision making process (e.g., substitute decision maker if the person is incapable)
 - Develop a plan of treatment related to disease management that takes into account the person's values and mutually determined goals of care
 - Obtain consent from the capable person or the substitute decision maker if the person is incapable for an end-of-life plan of treatment that includes:
 - Setting for care
 - Resuscitation status
 - Having, withholding and or withdrawing treatments (e.g. lab tests, medications, etc.)
- Screen for specific end of life psychosocial issues**
 - Specific examples of psychological needs include: anticipatory grief, past trauma or losses, preparing children (young children, adolescents, young adults), guardianship of children, death anxiety
 - Consider referral to available resources and/or specialized services
- Identify patients who could benefit from specialized palliative care services (consultation or transfer)**
 - Discuss referral with patients and family
- Proactively develop and implement a plan for expected death**
 - Explore place-of-death preferences and assess whether this is realistic
 - Explore the potential settings of dying and the resources required (e.g., home, residential hospice, palliative care unit, long term care or nursing home)
 - Anticipate/Plan for pain & symptom management medications and consider a Symptom Response Kit (SRK) for unexpected pain & symptom management
 - Preparation and support for family to manage
 - Discuss emergency plans with patient and family (who to call if emergency in the home or long-term-care or retirement home)
- Home care planning**
 - Connect with Home and Community Care early (not just for last 2-4 weeks)
 - Ensure resources and elements in place
 - Consider a Symptom Response Kit (SRK) with access to pain, dyspnea and delirium medication
 - Identify family members at risk for abnormal/complicated grieving and connect them proactively with bereavement resources

The pathway map is intended to be used for informational purposes only. The pathway map is not intended to constitute or be a substitute for medical advice and should not be relied upon in any such regard. Further, all pathway maps are subject to clinical judgment and actual practice patterns may not follow the proposed steps set out in the pathway map. In the situation where the reader is not a healthcare provider, the reader should always consult a healthcare provider if he/she has any questions regarding the information set out in the pathway map. The information in the pathway map does not create a physician-patient relationship between Cancer Care Ontario (CCO) and the reader.

